



CORNELL PUMP COMPANY

MANURE PUMPS



IMAGE COURTESY OF BAMBAUER EQUIPMENT



IMAGE COURTESY OF PUCK ENTERPRISES



EFFICIENT BY DESIGN





MP SERIES PUMPS

IMAGE COURTESY OF PHIL'S PUMPING



MP SERIES PUMPS ARE DESIGNED FOR COARSE ABRASIVES

The MP series offers exceptional wear resistance for reduced maintenance and long life in harsh environments.

MP SERIES	
DISCHARGE SIZE RANGE	2", 3", 4", 6", 8", 10"
MAX SOLIDS HANDLING	UP TO 4"
MAX FLOW	9,000 GPM
MAX HEAD	625'
SEAL TYPE	MECHANICAL SEAL WITH CYCLOSEAL®
IMPELLER	ENCLOSED
CONFIGURATIONS	HORIZONTAL FRAME AND SAE MOUNT

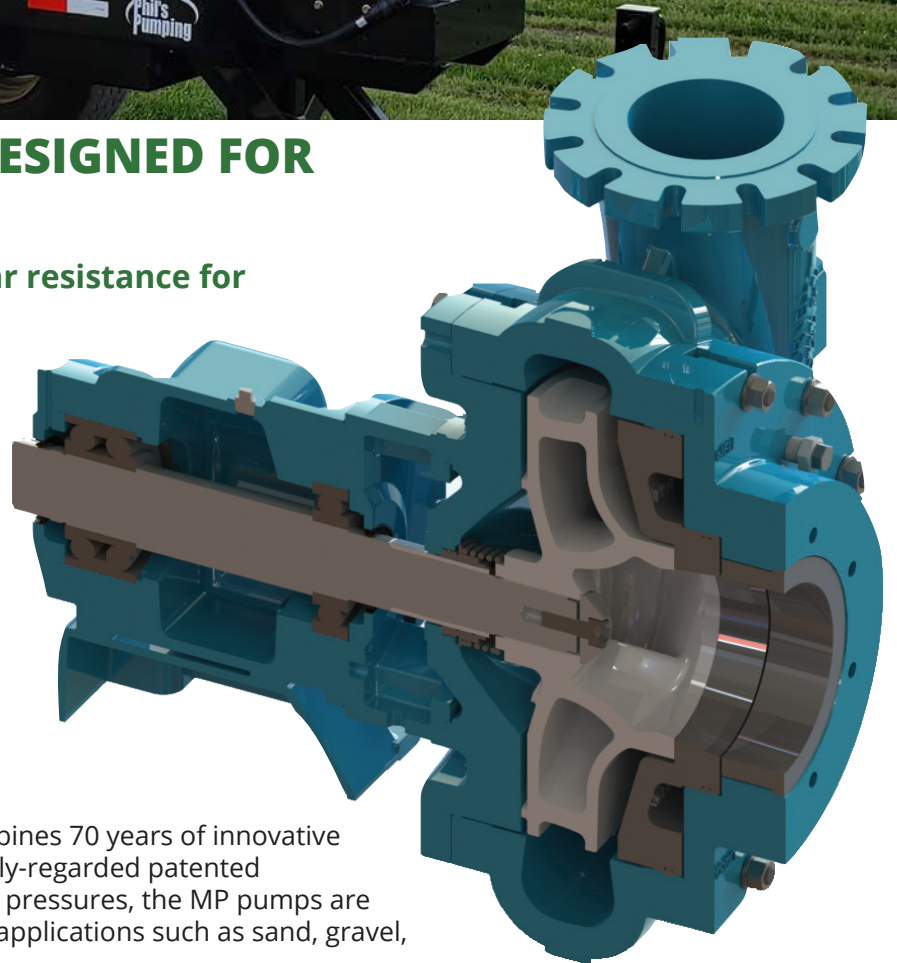

Cornell Pump Company's MP Pump Series combines 70 years of innovative pump manufacturing and design, with our highly-regarded patented Cyclo Seal® technology. Offering high operating pressures, the MP pumps are specifically designed for coarse abrasive slurry applications such as sand, gravel, and manure.

- Run-Dry™ and Redi-Prime® compatible
- High-chrome white iron or heat-treated ductile iron pump-end
- Thick cross-sections for abrasive wear and high operating pressures
- Front adjustable wear plate to regain lost efficiency while in service
- Replaceable suction liner and wear plates at point of maximum wear
- Heavy duty construction for aggressive applications with 17-4PH Stainless shaft
- Hardness rating > 600 BHN provides better wear properties compared to standard cast or ductile iron
- Heavy duty bearing frame with double angular contact thrust bearing. Oil or grease lubricated

MP SERIES PUMPS

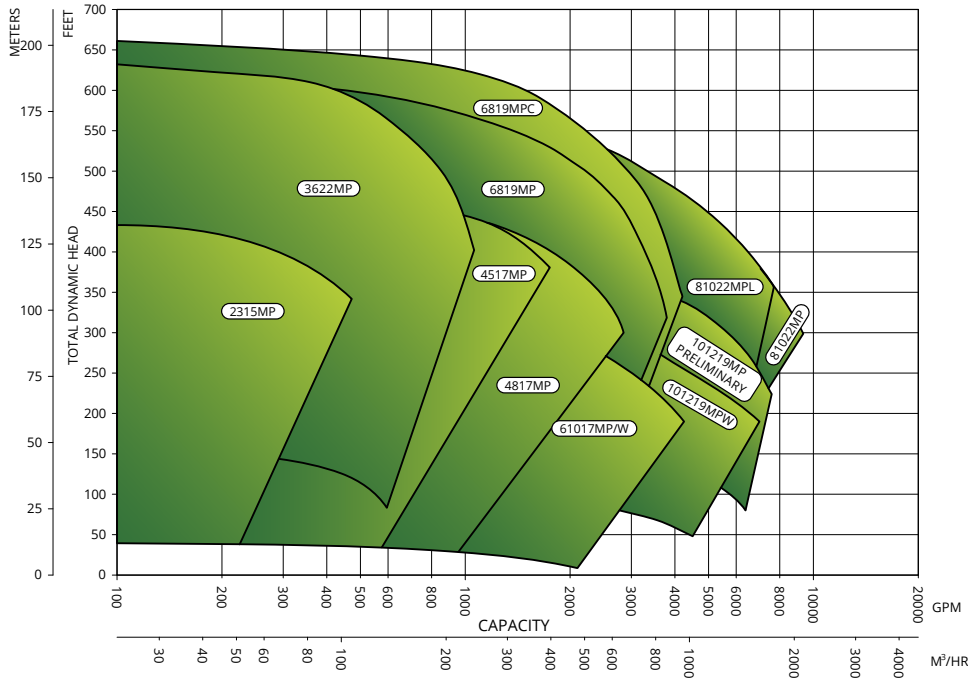

LONGER WEAR LIFE THAN
STANDARD CORNELL
SOLIDS HANDLING
PUMPS

HANDLES SOLIDS
UP TO 4"

WORKS IN TOUGH
ENVIRONMENTS

CORNELL'S PATENTED
CYCLOSEAL[®],
RUN-DRY[®], AND
REDI-PRIME[®] OPTIONS
ARE AVAILABLE

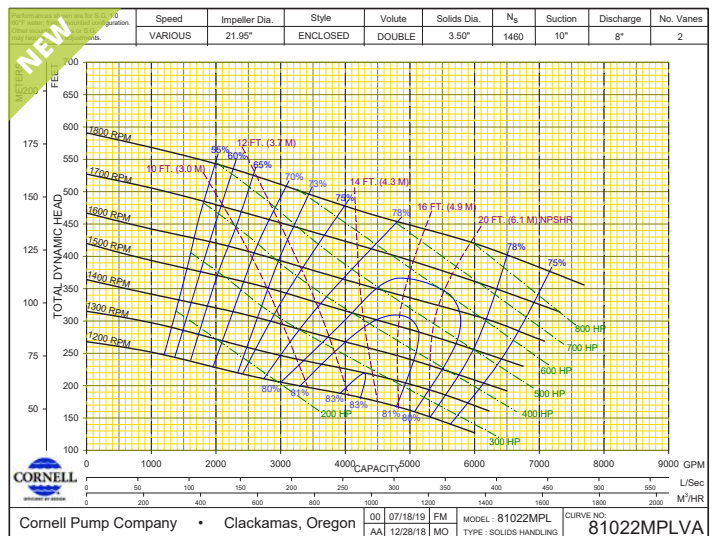
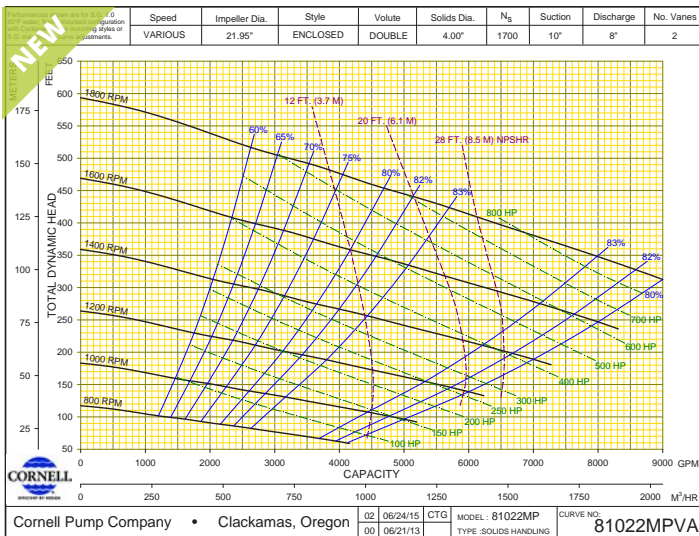
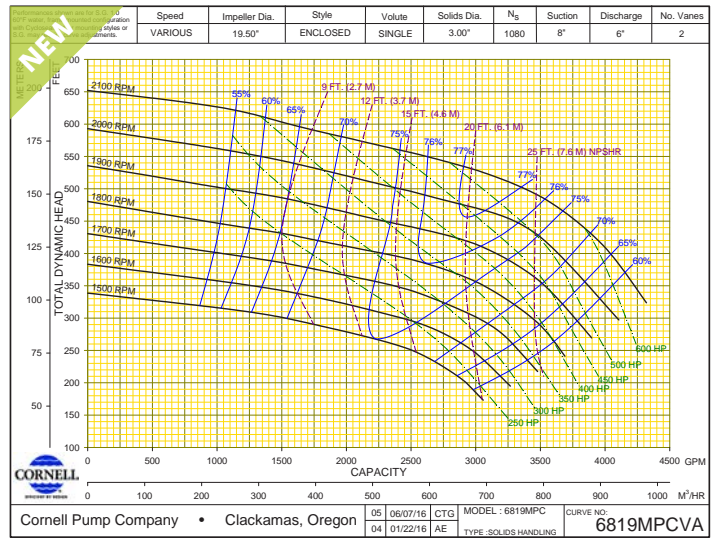
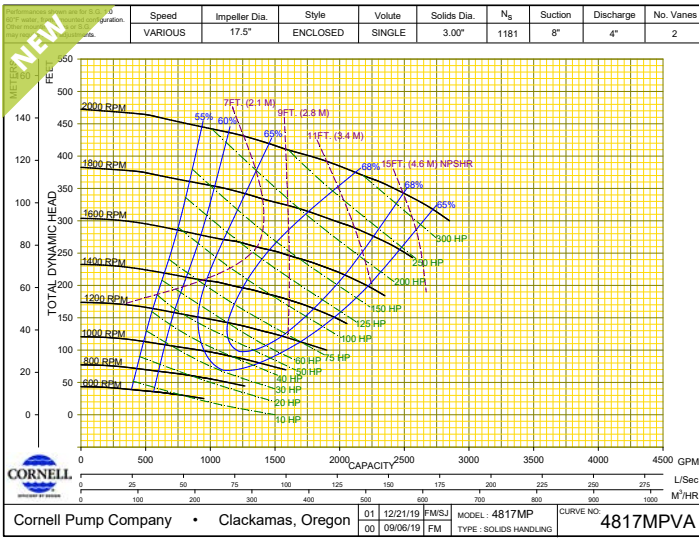



LEGACY MANURE PUMPS

IMAGE COURTESY OF BAZOOKA FARMSTAR



MANURE SLURRY PUMPS FOR TRANSFER, INJECTION & IRRIGATION

Cornell offers over 60 models of heavy duty Solids Handling Pumps for the toughest slurry applications.

LEGACY MANURE PUMPS	
DISCHARGE SIZE RANGE	3" - 30"
MAX SOLIDS HANDLING	3"
MAX FLOW	38,000 GPM
MAX HEAD	470'
SEAL TYPE	MECHANICAL SEAL WITH CYCLOSEAL®
IMPELLER	ENCLOSED, SEMI-OPEN, OR DELTA
CONFIGURATIONS	VARIED

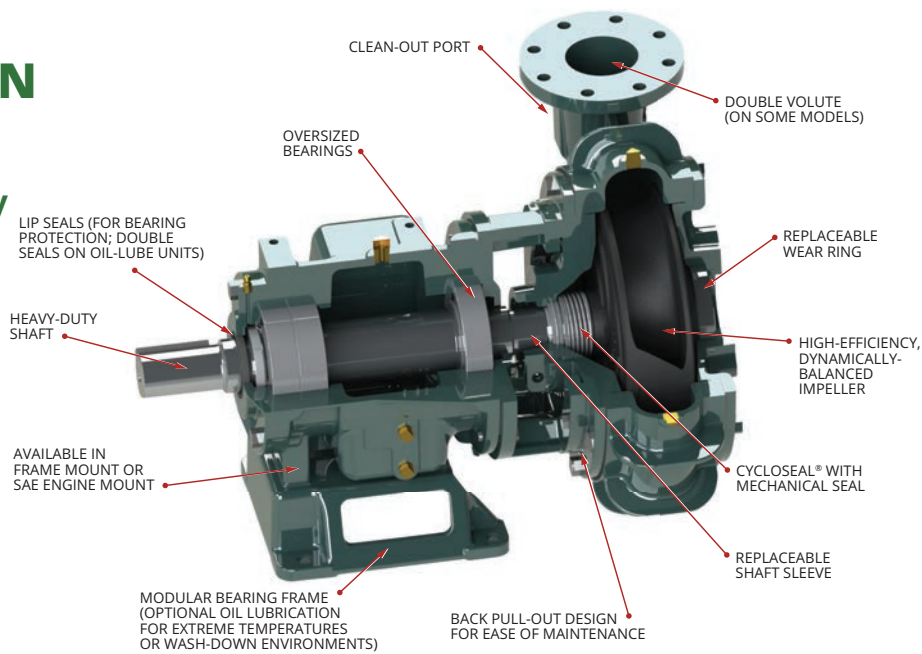

Cornell Manure Slurry pumps are iron or ductile iron construction with hard face mechanical seals for extended seal life. Optional materials are available for abrasive applications.

- High hydraulic efficiency
- Cycloseal® design
- Rigid, heavy walled construction
- Back pullout design
- Large bearings and shaft
- Impeller backvanes reduce axial thrust
- Replaceable wear rings and shaft sleeves
- Dynamically balanced impeller
- Low maintenance, long life
- Low power costs
- No seal venting or flushing required
- Ease of maintenance
- Smooth operating
- Solids handling capability
- Run-Dry®, Redi-Prime®, and cutter blades available
- Versatile mounting configurations

COMMON SOLIDS HANDLING PUMPS FOR MANURE APPLICATIONS

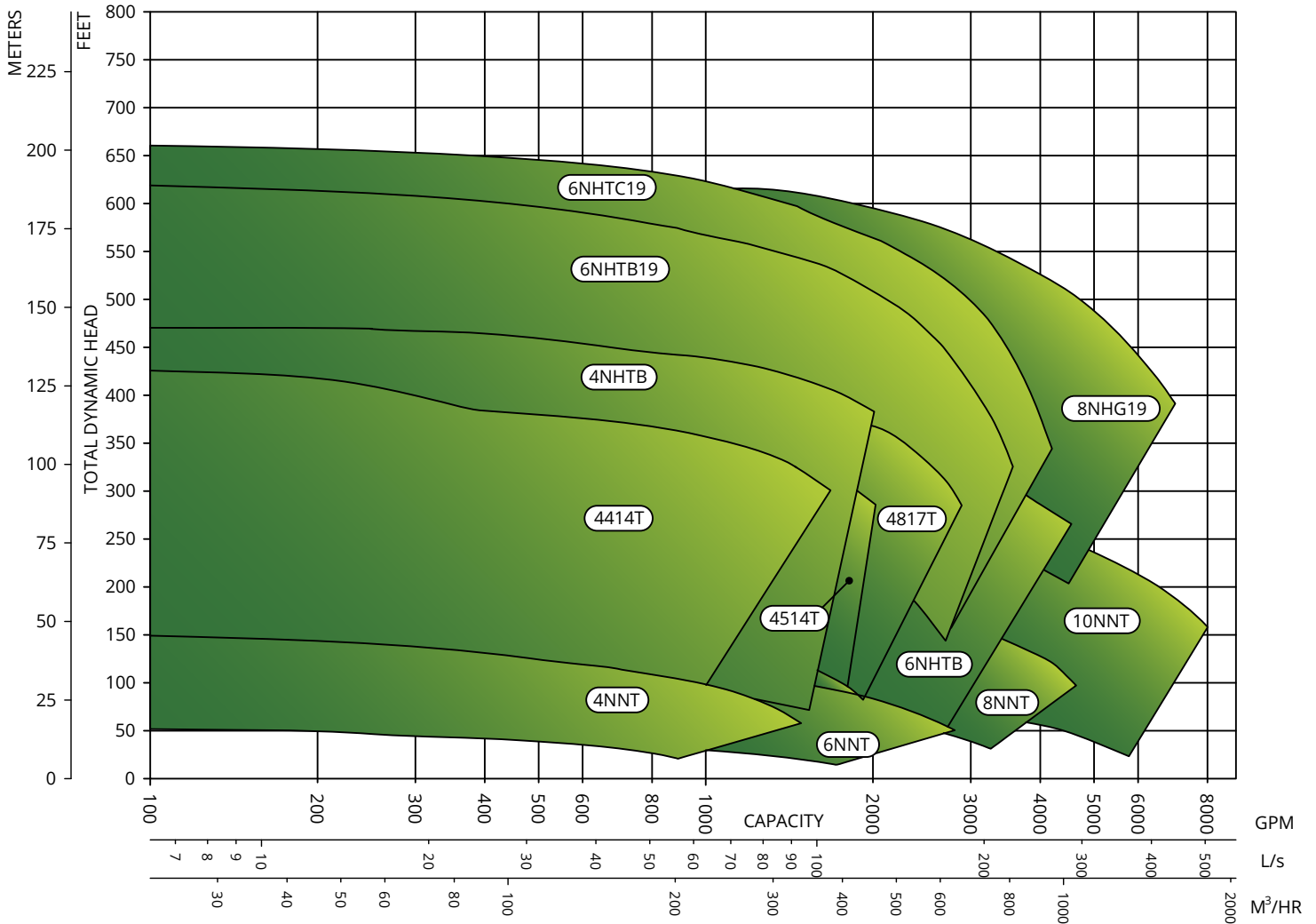

MATERIAL OPTIONS FOR SOLIDS HANDLING PUMPS

VARIOUS PROCESSES CAN BE MOST EFFECTIVELY ACCOMPLISHED WITH DIFFERENT METAL HARDNESSES. CORNELL IS PROUD TO PRODUCE OUR SOLIDS HANDLING PUMPS IN FOUR DIFFERENT HARDNESS LEVELS.

MATERIAL	STANDARD MATERIAL HARDNESS		HARDER	HARDEST
	Cast Iron	Ductile Iron	Heat Treated Ductile Iron	White Iron
TECHNICAL NAME(S)	ASTM A48, CL30	ASTM A536 100-70-03	ASTM A536 100-70-03 quench and temper	ASTM A532, CL III; Type A 25% CR level 1
CORNELL MATERIAL CODE	CI	CV	ZY	CAC
RELATIVE COST	\$	\$	\$\$	\$\$\$
HARDNESS	190-240 BHN	230-300 BHN	400-450 BHN	>600 BHN

Note: Wear resistance directly correlates to the hardness of the material.



SOLIDS HANDLING IMPELLERS

ENCLOSED TWO, THREE, AND FOUR PORT SPHERICAL SOLIDS

Large spherical solids pass through the pump while offering optimal head and efficiency.

- 2" or larger solids
- 3" to 30" discharge sizes
- Flows to 40,000 GPM and heads to 450'



THREE OR FOUR BLADED, SEMI-OPEN SLURRY

Cutting action allows the semi-open impeller to handle the worst slurries at high heads.

- 1" or larger soft solids
- 1.25" to 10" discharge size



DELTA STYLE

STRAW AND STRINGY MATERIALS

Trailing edges on impeller vanes reduce low pressure areas. Vortices are created which pass solids through the impeller. No "hair pinning" or hang-up of stringy materials. Larger solids are broken up.

- For difficult solids
- 3" to 10" discharge size
- Flows to 5000 GPM and heads to 400'

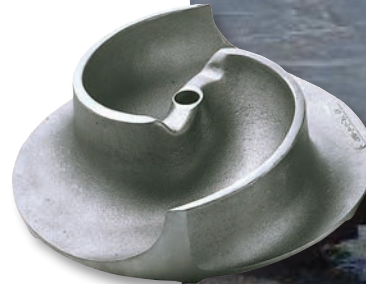

BLADE CUTTER

CLOGGING MATERIALS

Rotating and stationary cutter blades mounted on the suction end break up clogs and stringy material before they reach the impeller while keeping efficiencies as high as possible.

- Minimal energy consumption (4% or less)
- Hardened, adjustable cutter blades
- Minimize flow restrictions



WASTE WARRIOR CUTTER SEVERE CLOGGING

A more aggressive solution to help eliminate troublesome clogs caused by stringy material. A scythe-like edge sweeps the area where the suction pipe meets the volute to keep materials from clogging in the impeller area.

- Limited energy consumption (around 8%)
- Hardened cutter blades
- Insignificant flow restrictions



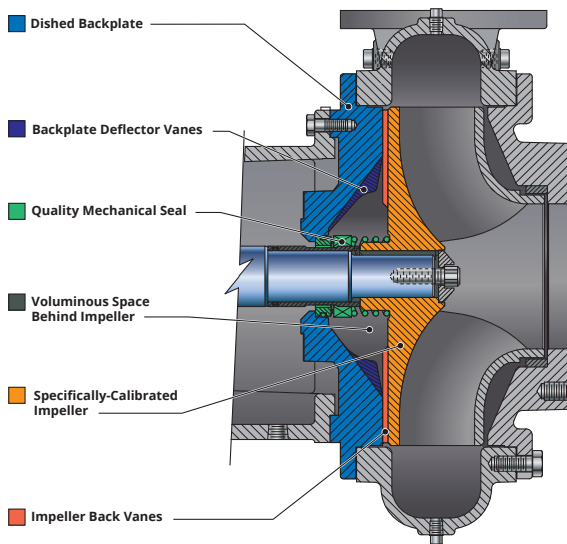

CYCLOSEAL® SYSTEM FOR GRIT REMOVAL

Cycloseal is a patented system with a self-contained single mechanical seal with a dished line. The Cycloseal pattern cast into the pump backplate in conjunction with contoured impeller back vanes and a dished backplate creates pressure gradients that move solids and entrained vapor away from the seal faces. The Cycloseal system is only available on Cornell pumps.

- Removes grit from pump seal compartment
- Extends pump seal life three times standard mechanical
- No drips/mess at application site
- Reduced maintenance costs
- Increased uptime and reliability

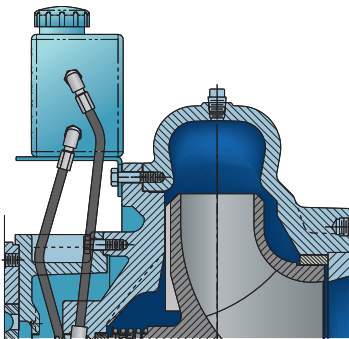

RUN-DRY™ SEAL PROTECTION SYSTEM

Cornell's Run-Dry system consists of an auxiliary gland and oil reservoir that keeps the seal faces lubricated and prevents dry running of the seal faces during priming, re-priming, or standby operation.

- Run dry for hours without damaging the seal
- Cools and lubricates seal faces
- Ideal for applications that could operate in a dry condition
- Useable in conjunction with Cycloseal® and Redi-Prime®



STX/H/L SELF-PRIMING PUMPS

STX/STL/STH Series of popular self-primers to have the best efficiencies in the industry. Using Combined with our patented-Cycloseal® back plate technology, the pumps are durable, powerful, and energy efficient. Heads up to 253' and efficiencies to 68%. Simple to operate, Cornell Self Priming series are wet-primed (fluid in the pump cavity at initial operation), then self-priming as long as there is water above the eye of the impeller.

HYDRAULIC SUBMERSIBLE PUMPS

Many of Cornell's solids handling models can be configured as hydraulic submersible pumps. The modular design couples a Cornell high-efficiency pump end with a heavy-duty bearing frame and reliable hydraulic motor.

- Heavy duty shaft / bearing frame assembly and wet end construction
- Premium wet end efficiencies reduce horsepower requirements
- Solids handling >3"
- Heads up to 360' / Flows up to 7000 GPM





MARKET AND PRODUCT LINE



AGRICULTURE



FOOD PROCESS



INDUSTRIAL



MINING



MUNICIPAL

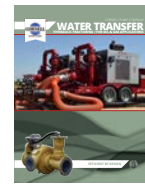

WATER TRANSFER



REFRIGERATION



CONSTRUCTION



SLURRY



SLURRY SM

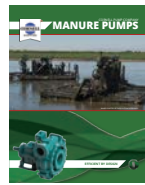

MANURE

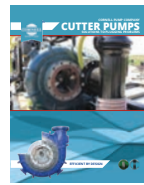

CUTTERS



SELF PRIMING



HIGH FLOW



MX SERIES



N SERIES



CYCLONE™



EDGE™



HYDRAULIC SUBS



IMMERSIBLE



CD4MCU



RUN-DRY™



PRIMING SYSTEMS



CYCLOSEAL®

Cycloseal® and Redi-Prime® are Registered Trademarks of Cornell Pump Company.

Cornell pumps and products are the subject of one or more of the following U.S. and foreign patents:
6,074,554; 6,036,434; 6,079,958; 6,309,169.

CORNELLPUMP.COM
©2019 CORNELL PUMP COMPANY



Cornell Pump Company
Clackamas, Oregon, USA
P: +1 (503) 653-0330
F: +1 (503) 653-0338

AUTHORIZED CORNELL PUMP DISTRIBUTOR